

... Continued

Insert Button Head Bolts (Provided) thru bottom of Roll Rim into Tube and tighten. **Figure 6.**

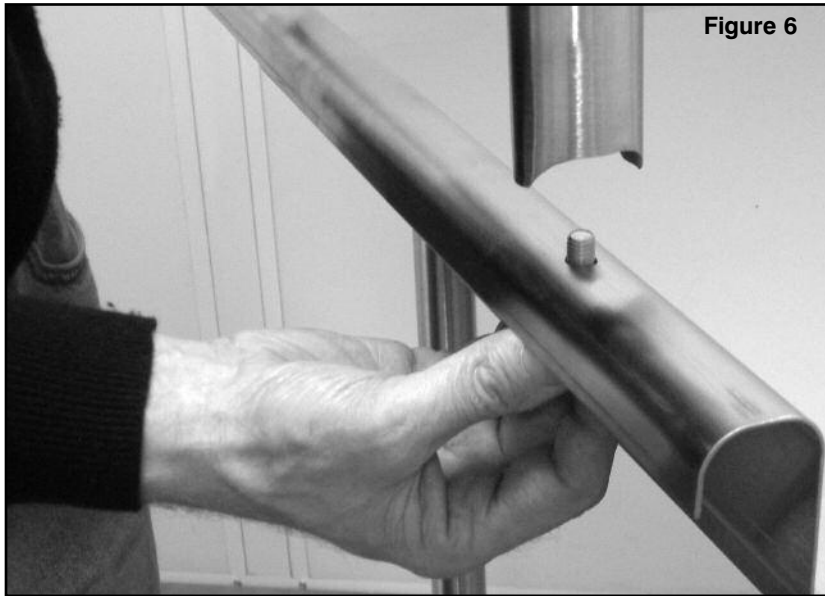

Figure 6

Step 4:

Tighten all Bolts. Seal Joints with N.S.F. Approved Silicone Sealant where Notched Uprights meet Roll Rim (Where uprights pass thru elliptical holes in backsplash and Bolt Heads) **Figure 7.**

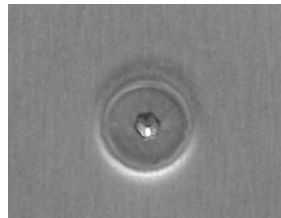

Figure 7



Edgewood, New York 11717-8380

JULY 2009



Installation Instructions for **TABLE MOUNTED SORTING SHELVES**

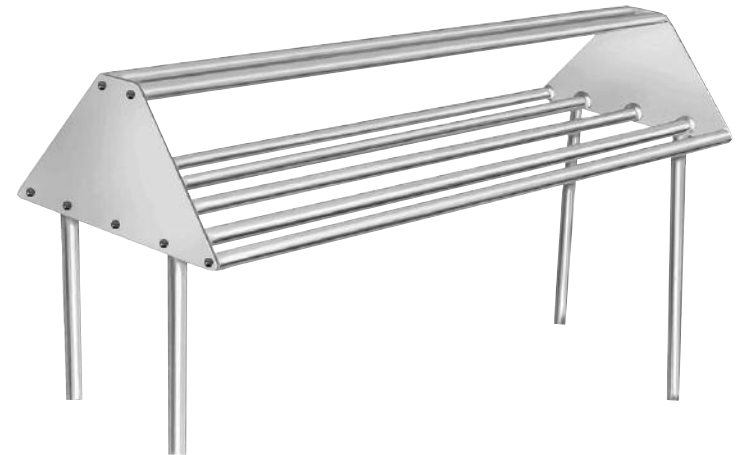

**CHECK FOR CONCEALED DAMAGE
FILE CLAIM WITH DELIVERING FREIGHT CARRIER**

Table Mounted Sorting Shelves manufactured by **ADVANCE TABCO®** are designed and constructed store/drain Dish Racks used in a Commercial Dishwasher. **ADVANCE TABCO®** does not recommend use for activities employing harsh and active chemicals. Please consult factory regarding unusual applications.

INSTALLATION INSTRUCTIONS

Contents:

- (2) End Panels
 - (5) Stainless Steel Cross Tubes
 - (2) Cross Tubes with Welded Tubular Uprights
- Mounting Hardware:
(14 Flat Head Bolts + 4 Button Head Bolts)

Tools Required:

7/32" Allen Wrench

NOTE:

DTA-79 May come Pre-Assembled From Factory Where Special Applications Exist

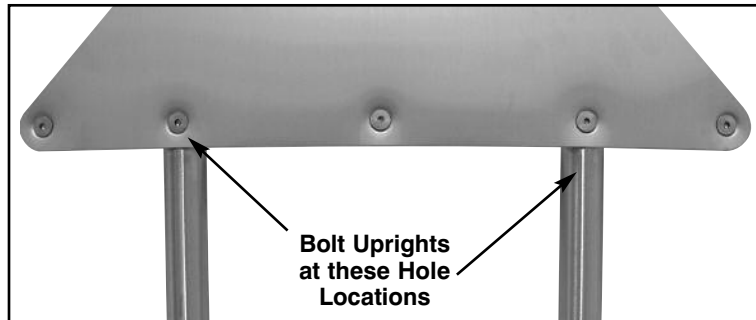

Figure 1

Step 1:

Align (2) Cross Tube's with welded Tubular Upright at the Second Hole in on each End Panel. Secure with Flat Head Bolts provided (**Figure 1**).

NOTE: Ensure Cross Tubes with Welded Uprights match at each end.

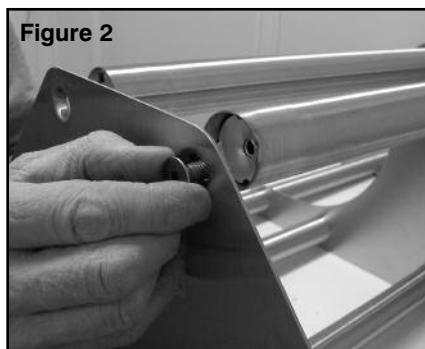

Figure 2

Step 2:

Align remaining (5) Cross Tubes between End Panels - Secure with Flat Head Bolts provided (**Figure 2**).

Step 3:

Mount DTA-79 to Dishtable - Align Notched posts with holes in roll rim (**Figure 3**) and Flat Bottom Posts with Elliptical Holes in Backsplash (**Figure 4**). Slide Uprights thru Elliptical Holes so Posts rests on Bracket and Notched Uprights rest on Roll Rim.

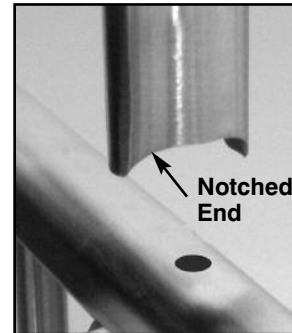

Figure 3

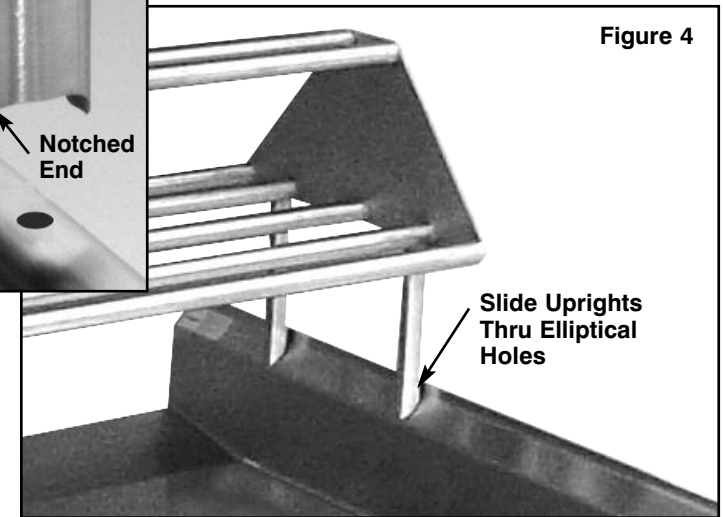

Figure 4

Insert Button Head Bolts (Provided) thru Brackets into Tubes and tighten (**Figure 5**).



Figure 5

Continued...